

INSTALLING AND ADJUSTING NEW VALVES.

REVERSER, LINE BREAKER AND "ON" MAGNET VALVES.

First, place the .052" gauge (Cat.#1419137) around the exhaust valve stem. Then press down on the valve stem. When the exhaust valve seats (i.e., air does not pass thru the valve), the top of the valve stem should be flush with the surface of the gauge. If it is not flush, it should be shortened or lengthened until it is flush.

Second, place the .036" gauge (Cat.#1419136) on top of the .052" gauge. If the inlet valve stem is the proper length, the upper or exhaust valve stem will be just flush with the gauges, and, when the armature is pressed down, no action will result (i.e., air will not pass thru the inlet valve). If the upper valve stem is above the surface of the gauges, a small amount should be filed off the inlet valve stem. If the upper valve stem is below the surface of the gauges, a new inlet valve with a longer stem should be put in.

Third, replace the .036" gauge with the .020" gauge, and press down on the exhaust stem with the armature. Air should pass thru both the inlet and exhaust valves.

ADJUSTING "OFF" MAGNET VALVE.

First, place the .052" and .036" gauges around the plunger. If the plunger and exhaust valve stem are the proper length, the top of the plunger will be flush with the gauges, and, when the armature is pressed down on the plunger, air will not escape from the exhaust valve. If the top of the plunger is above the surface of the gauges, either the plunger or the exhaust valve stem should be shortened. If the plunger is below the surface of the gauge, either the plunger or exhaust valve stem is too short and a new one should be used.

Second, remove the .036" gauge.

Press the armature on the plunger; this should seat the inlet valve (i.e., air should not pass thru the valves). If the valves are the proper length, the top of the plunger will be flush with the surface of the .052" gauge. If the plunger is above the surface of the gauge, remove the inlet valve seat and place additional paper washers between the valve seat and valve casing until the top of the plunger is flush with the surface of the .052" gauge, with the plunger pressed down. If the top of the plunger is below the surface of the gauge, either use a new valve or make a metal washer, which should be placed between the inlet and exhaust valves, increasing the length between these valves.

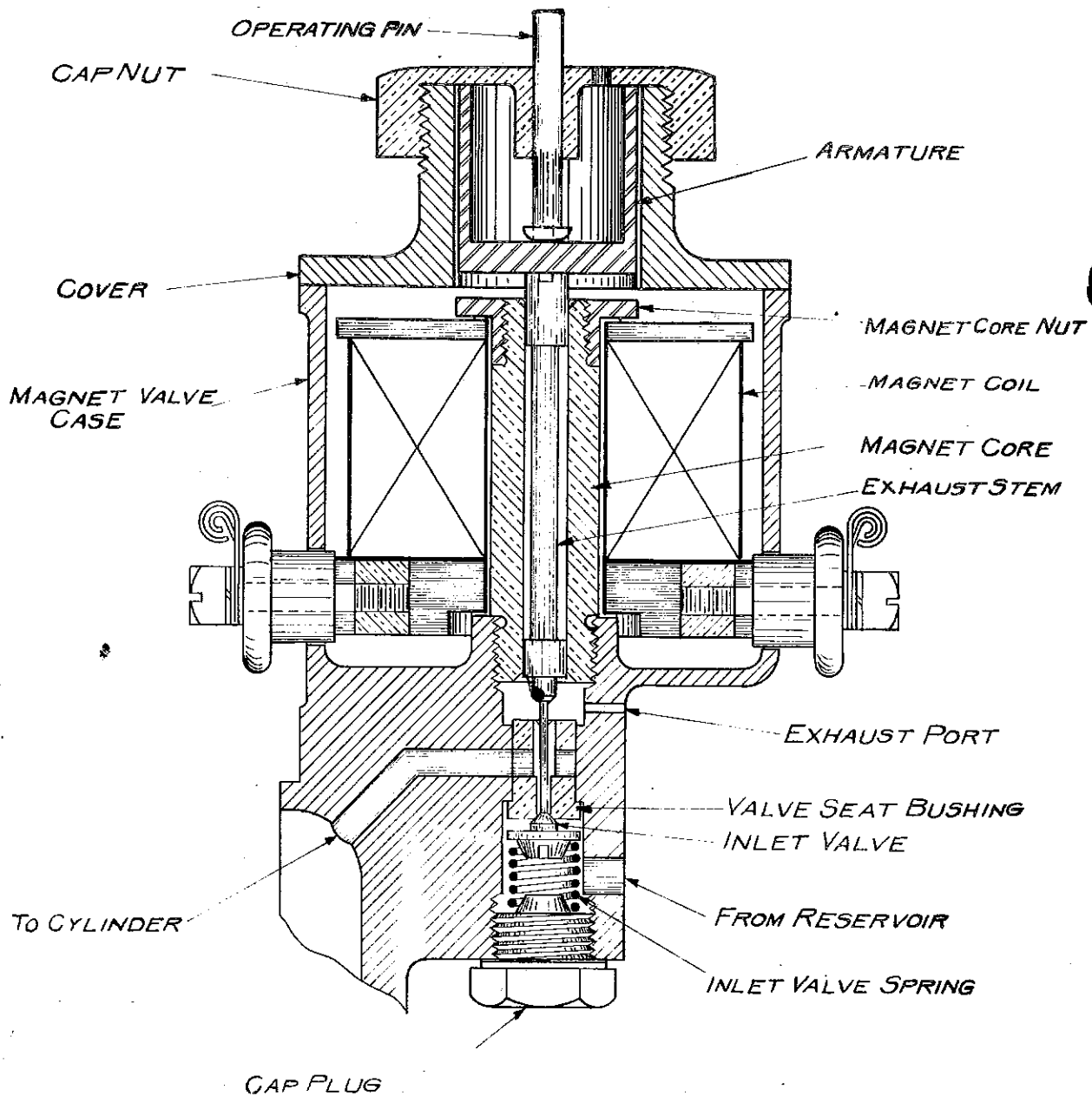

234829 MAGNET VALVE FOR REVERSER, LINE BREAKER AND "CN" CYLINDER.
 INDEX E-353.7

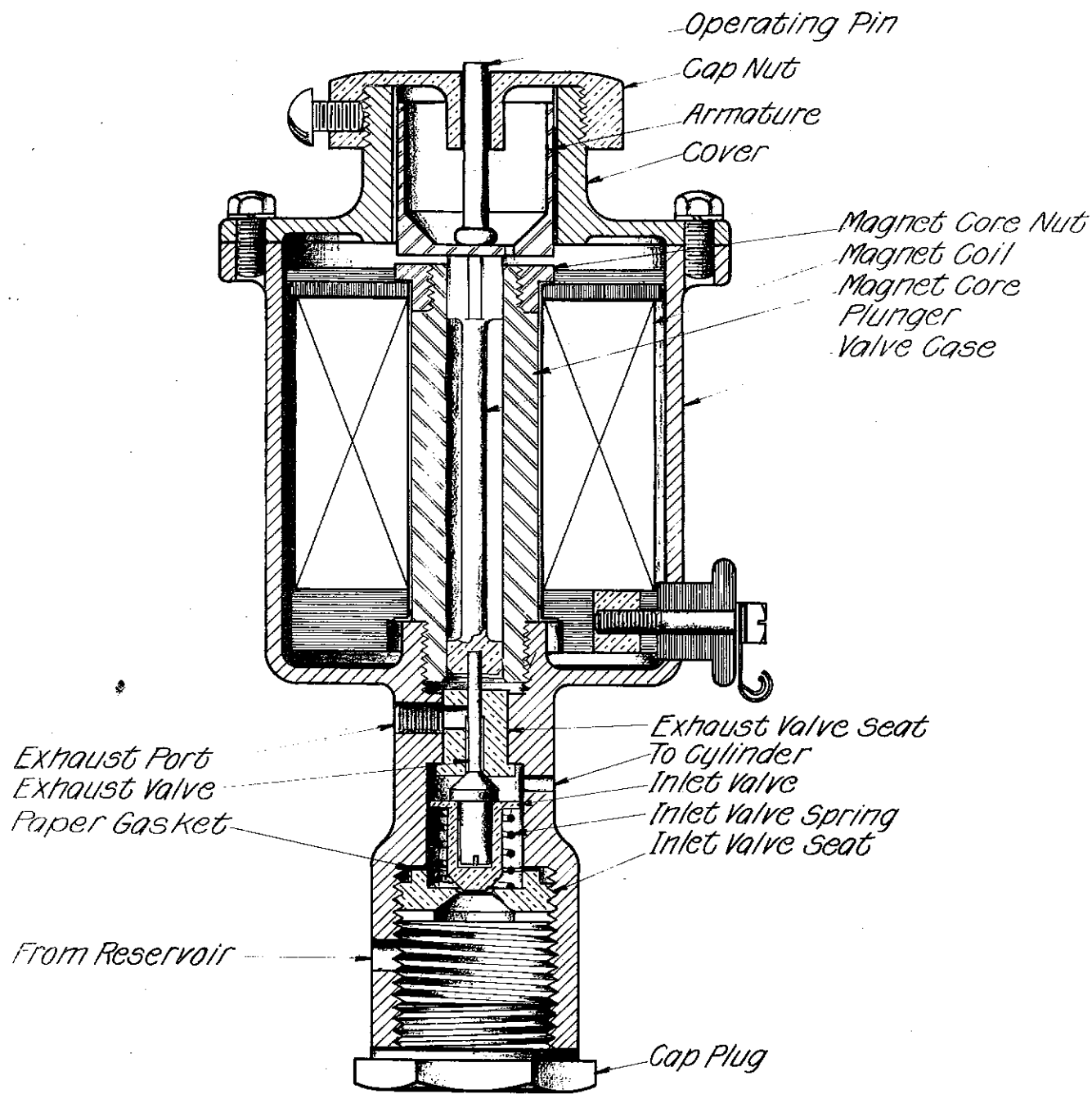

MAGNET VALVE FOR "OFF" CYLINDER.
 INDEX 5. 3. 17