

COPYRIGHT, 1908, BY THE

# Westinghouse Traction Brake Company.

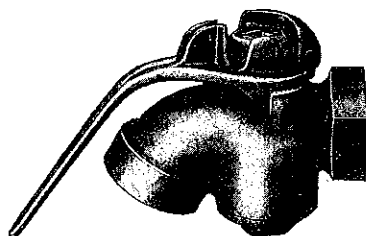

## Cocks.

Part Catalog No. T 3516-4. November, 1912.

(SUPERSEDING ISSUE OF OCTOBER, 1908.)

ANGLE COCKS.

SELF-LOCKING ANGLE COCKS.

Self-locking Angle Cocks are now standard and are furnished with all complete locomotive, passenger car and freight car brake equipments unless otherwise specified on orders.

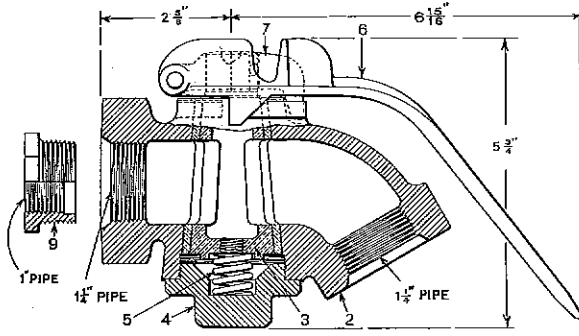

Net Weight, 10 lbs.

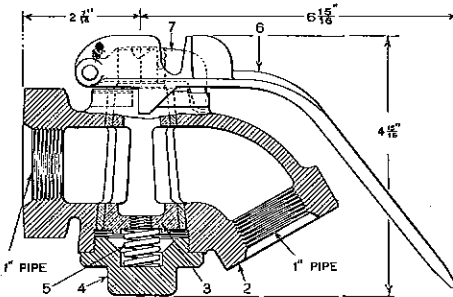

Net Weight, 6 1/2 lbs.

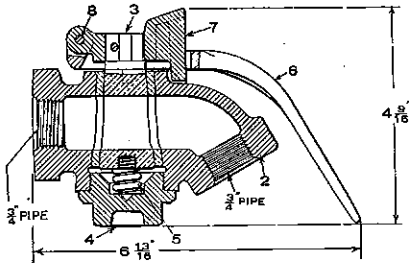

Net Weight, 4 1/4 lbs.

Piece No. 22413. 1 1/4-inch Self-Locking Angle Cock, complete  
Price, \$1.80

Piece No. 22412. 1-inch x 1 1/4-inch Self-Locking Angle Cock, complete (includes 9)  
Price, \$1.80

Pc. No.	Ref. No.		Price
2176	2	Body, bushed . . . .	\$ .90
2096	3	Key . . . . .	.40
2097	4	Cap . . . . .	.10
2098	5	Spring . . . . .	.03
20128		Handle, complete (includes 6 and 7)	.40
20127	6	Handle, only . . . . .	.25
20126	7	Handle Socket . . . . .	.15
2178	9	1 1/4-inch x 1-inch Bushing . . . . .	.05

Piece No. 22416. 1-inch Self-Locking Angle Cock, complete  
Price, \$1.60

Pc. No.	Ref. No.		Price
14866	2	Body, bushed . . . .	\$ .75
14864	3	Key . . . . .	.35
2140	4	Cap . . . . .	.10
2098	5	Spring . . . . .	.03
20128		Handle, complete (includes 6 and 7)	.40
20127	6	Handle, only . . . . .	.25
20126	7	Handle Socket . . . . .	.15

Piece No. 18309. 3/4-inch Self-Locking Angle Cock, complete  
Price, \$1.50

Pc. No.	Ref. No.		Price
14910	2	Body, bushed . . . .	\$ .70
2236	3	Key . . . . .	.30
14897	4	Cap . . . . .	.10
2145	5	Spring . . . . .	.03
17833		Handle, complete (includes 6 and 7)	.40
17832	6	Handle, only . . . . .	.25
17831	7	Handle Socket . . . . .	.15

NOTE—The old style plain angle cock handle, Piece No. 2102, Price, \$ .08, having been superseded by the self-locking style, is now no longer furnished unless specified on orders. In all other details except the handle the old style angle cock is the same as the self-locking type as listed above.

Orders must give PIECE NUMBER and NAME of part wanted.

CUT-OUT COCKS.

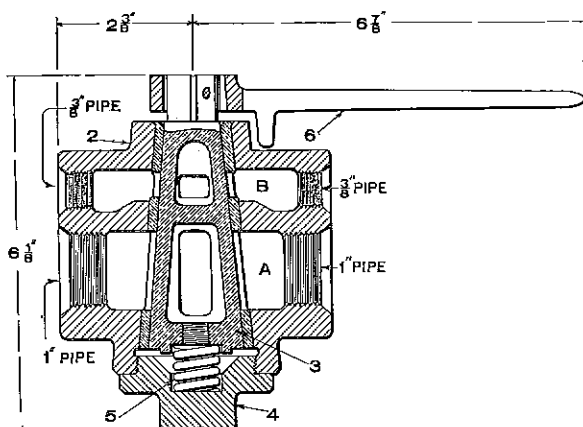

Net Weight, 9 lbs.

DOUBLE CUT-OUT COCK.

This cock, furnished with Schedules AMM, AMR and AML, is used only for cutting out the control and brake pipe branch connections to the triple valve.

Piece No. 9517. 3/8-inch and 1-inch Double Cut-out Cock, complete . . . . . Price, \$3.00

Pc. No.	Ref. No.	Price
9516	2 Body, bushed . . . . .	\$1.75
9515	3 Key . . . . .	1.00
2097	4 Cap . . . . .	.10
2098	5 Spring . . . . .	.03
10897	6 Handle . . . . .	.10

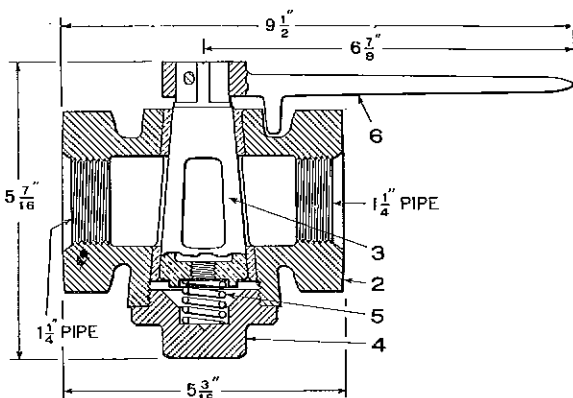

Net Weight, 8 1/2 lbs.

CUT-OUT COCKS.

Piece No. 2092. 1 1/4-inch Cut-out Cock, complete . . . . . Price, \$1.30

Pc. No.	Ref. No.	Price
2093	8 Body, bushed . . . . .	\$.70
2096	9 Key . . . . .	.40
2097	10 Cap . . . . .	.10
2098	11 Spring . . . . .	.03
2100	12 Handle . . . . .	.07

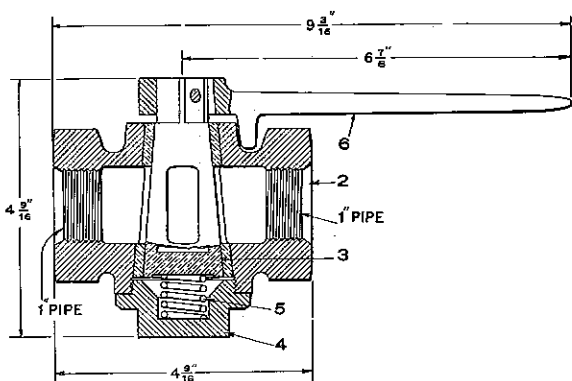

Net Weight, 5 1/2 lbs.

Piece No. 2135. 1-inch Cut-out Cock, complete . . . . . Price, \$1.20

Pc. No.	Ref. No.	Price
2136	2 Body, bushed . . . . .	\$.70
2139	3 Key . . . . .	.35
2140	4 Cap . . . . .	.10
2098	5 Spring . . . . .	.03
2103	6 Handle . . . . .	.07

NOTE—Cut-out-Cocks of both the 1" and 1 1/4" sizes can be furnished with Self-Locking Handles, if so desired. These Self-Locking Handles are similar to our standard Self-Locking Angle Cock Handles, except that the Cut-out-Cock Handle is straight instead of curved. The Self-Locking Handle can also be applied to Cut-out Cocks now in service. When ordering these Handles, orders should specify as follows:

Pc. No.	Price
33073 1-inch Self-Locking Out-out Cock, complete . . . . .	\$1.50
32930 Self-Locking Handle, complete, for 1-inch Cut-out Cock . . . . .	.40
33072 1 1/4-inch Self Locking Cut-out-Cock, complete . . . . .	1.60
37691 Self-Locking Handle, complete, for 1 1/4-inch Cut-out Cock . . . . .	.40

Orders must give PIECE NUMBER and NAME of part wanted.

CUT-OUT COCKS—Continued.

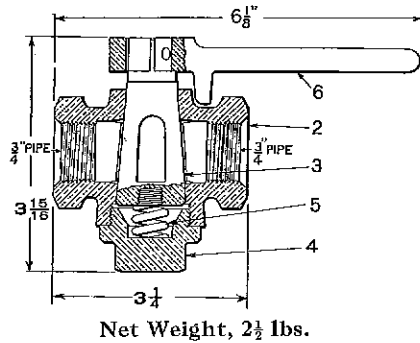

Piece No. 2233.  $\frac{3}{4}$ -inch Cut-out  
Cock, complete  
Price, \$1.10

Pc. No.	Ref. No.	Price
2235	2 Body	\$ .60
2236	3 Key	.30
2144	4 Cap	.15
2145	5 Spring	.03
15279	6 Handle	.05

Piece No. 14494.  $\frac{3}{4}$ -inch Cut-out  
Cock, with Choke  
Fitting, complete  
Price, \$1.20

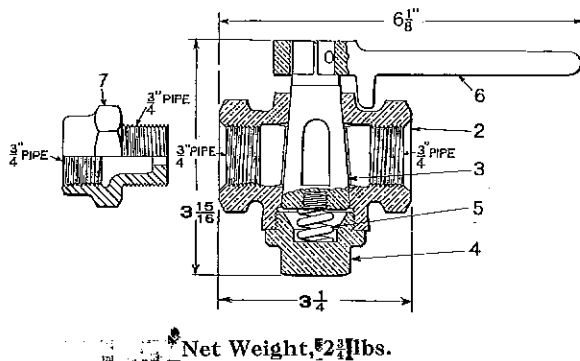

$\frac{3}{4}$ -inch Cut-out Cock with Choke Fitting is furnished with EL Electric Locomotive Brake Equipments, for use in brake cylinder pipe. All details except the choke fitting are the same as the standard  $\frac{3}{4}$ -inch Cut-out Cock listed above. The size of opening through the choke fitting varies according to the size and number of cylinders with which it is used. When ordering repair parts this information should accompany the order.

Pc. No.	Ref. No.	Price
11644	7 Choke Fitting	\$ .10

Piece No. 15213.  $\frac{1}{2}$ -inch Cut-out  
Cock, complete  
Price, \$ .90

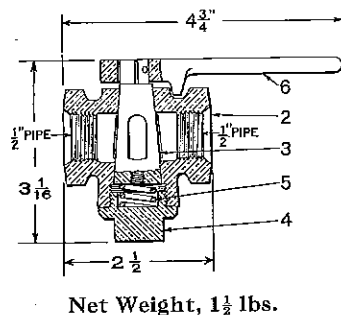

Pc. No.	Ref. No.	Price
2228	2 Body	\$ .50
2229	3 Key	.25
2367	4 Cap	.05
2231	5 Spring	.03
9035	6 Handle	.04

Piece No. 14493.  $\frac{1}{2}$ -inch Cut-out  
Cock, with Choke  
Fitting, complete  
Price, \$1.00

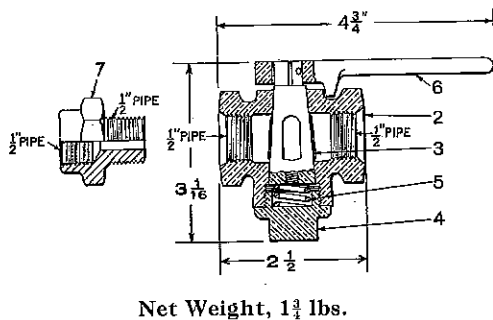

$\frac{1}{2}$ -inch Cut-out Cock with Choke Fitting is furnished with EL Electric Locomotive Brake Equipment, for use in brake cylinder pipe. All details except choke fitting are the same as the standard  $\frac{1}{2}$ -inch Cut-out Cock as listed above. The size of opening through the choke fitting varies according to the size and number of cylinders with which it is used. When ordering for repair parts this information should accompany the order.

Pc. No.	Ref. No.	Price
11645	7 Choke Fitting	\$ .10

Orders must give PIECE NUMBER and NAME of part wanted.

CUT-OUT COCKS—Continued.

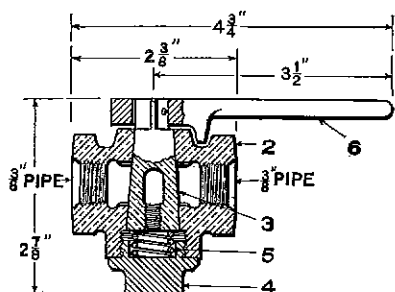

Net Weight, 1 1/2 lbs.

Piece No. 9053. 3/8-inch Cut-out Cock, complete . . . . . Price, \$ .90

Pc. No.	Ref. No.		Price
9055	2	Body . . . . .	\$ .50
9056	3	Key . . . . .	.25
2367	4	Cap . . . . .	.05
2231	5	Spring . . . . .	.03
9035	6	Handle . . . . .	.04

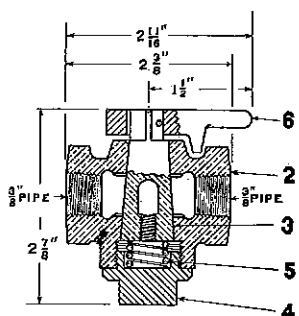

Net Weight, 1 1/4 lbs.

Piece No. 22459. 3/8-inch Cut-out Cock, with Short Handle, complete . . . . . Price, \$ .90

Furnished as part of "Dead-Engine" feature of EL Electric Locomotive Equipment.

Pc. No.	Ref. No.		Price
9055	2	Body . . . . .	\$ .50
9056	3	Key . . . . .	.25
2367	4	Cap . . . . .	.05
2231	5	Spring . . . . .	.03
22458	6	Handle . . . . .	.04

NOTE—We strongly recommend that all angle and cut-out-cocks be returned to us at Wilmerding, Pa., or to the American Brake Company, St. Louis, Mo. for repairs, since we have exceptional facilities for handling this work in quantity at a low cost (see Circular Notice No. 1033) and maintaining standards, so important to Air brake Apparatus. However, we will furnish, if desired, repair sizes of both angle and cut-out cock keys as follows:

1 1/4" ANGLE AND CUT-OUT COCK KEYS.

Pc. No.	Diameter at Large End	List Price Each
33303	1.6025 Minimum	\$ .40
33304	1.626	
2096	1.65 Standard	
33305	1.676	
29543	1.702 Maximum	

1" CUT-OUT COCK KEYS.

Pc. No.	Diameter at Large End	List Price Each
34948	1.433 Minimum	\$ .35
2139	1.453 Standard	
34949	1.473 Maximum	

3/4" CUT-OUT COCK KEYS.

Pc. No.	Diameter at Large End	List Price Each
34946	1.171 Maximum	\$ .30
2236	1.191 Standard	
34947	1.211 Maximum	

1/2" CUT-OUT COCK KEYS.

Pc. No.	Diameter at Large End	List Price Each
34944	.800 Minimum	\$ .25
2229	.820 Standard	
34945	.840 Maximum	

Orders must give PIECE NUMBER and NAME of part wanted.

MISCELLANEOUS COCKS.

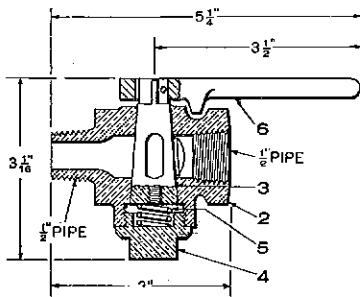

Net Weight, 1 1/2 lbs.

DRAIN COCKS.

Piece No. 7716. 1/2-inch Drain Cock, complete . . . . . Price, \$ .90

Pc. No.	Ref. No.		Price
7718	2	Body . . . . .	\$ .50
2229	3	Key . . . . .	.25
34086	4	Cap . . . . .	.15
2231	5	Spring . . . . .	.03
9035	6	Handle . . . . .	.04

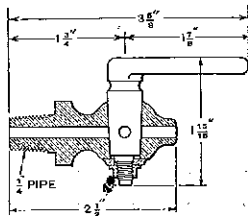

Net Weight, 1/2 lb.

Piece No. 41814. 1/4-inch Drain Cock, . . . . . Price, \$ .40

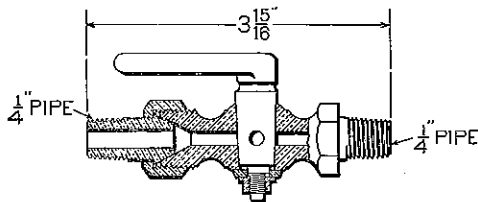

Net Weight, 1/2 lb.

1/4-INCH COCKS.

Piece No. 1887. 1/4-inch Cock with Union Connection for 1/4-inch Iron Pipe . . . Price, \$ .75

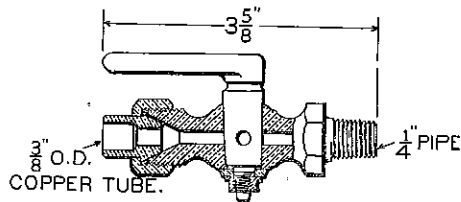

Net Weight, 1/2 lb.

Piece No. 24333. 1/4-inch Cock with Union Connection for 3/8-inch O. D. Copper Pipe . . . Price, \$ .75

Orders must give PIECE NUMBER and NAME of part wanted.

$\frac{1}{4}$ -INCH COCKS—Continued.

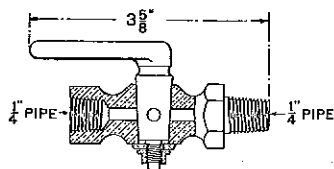

Net Weight,  $\frac{1}{2}$  lb.

Piece No. 11928.  $\frac{1}{4}$ -inch Cock with one end threaded and other end tapped . Price, \$ .50

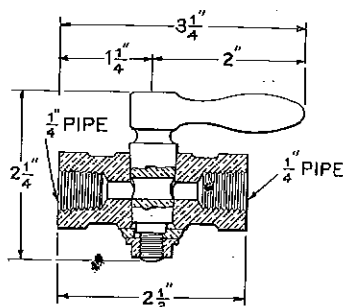

Net Weight,  $\frac{1}{2}$  lb.

Piece No. 16623.  $\frac{1}{4}$ -inch Cock with both ends tapped . . . . . Price, \$ .75

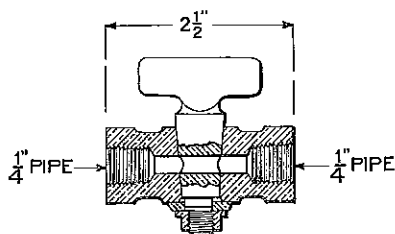

Net Weight,  $\frac{1}{2}$  lb.

Piece No. 19410.  $\frac{1}{4}$ -inch Cock with Tee Handle . . . . . Price, \$ .75

$\frac{1}{4}$ -INCH COCK HANDLES.

$\frac{1}{4}$ -inch Cocks, Piece Nos. 41814, 1887, 24333 and 11928, having flat lever handles, are closed when handle is parallel with pipe. Those having round lever or tee handles, Piece Nos. 16623 and 19410, are open when handle is parallel with pipe.

Orders must give **PIECE NUMBER** and **NAME** of part wanted.

# Westinghouse Traction Brake Company,

Pittsburg, Pa., U. S. A.

WORKS AT WILMERDING, PA.

## OFFICES:

ATLANTA	-	-	-	-	-	-	-	-	-	-	-	Candler Building
BOSTON	-	-	-	-	-	-	-	-	-	-	-	Exchange Building
CHICAGO	-	-	-	-	-	-	-	-	-	-	Railway	Exchange Building
CLEVELAND	-	-	-	-	-	-	-	-	-	-	-	Schofield Building
COLUMBUS	-	-	-	-	-	-	-	-	-	-	Columbus Savings and Trust Building	
DENVER	-	-	-	-	-	-	-	-	-	-	-	Tramway Building
HOUSTON, TEX.	-	-	-	-	-	-	-	-	-	-	-	3309 Smith Street
LOS ANGELES	-	-	-	-	-	-	-	-	-	-	-	Lissner Building
MEXICO CITY, MEXICO	-	-	-	-	-	-	-	-	-	-	4a Puente de Alvarado, No. 100	
NEW YORK	-	-	-	-	-	-	-	-	-	-	-	City Investing Building
PITTSBURGH	-	-	-	-	-	-	-	-	-	-	-	Westinghouse Building
PORTLAND, ORE.	-	-	-	-	-	-	-	-	-	-	-	Spalding Building
ST. LOUIS	-	-	-	-	-	-	-	-	-	-	-	Security Building
ST. PAUL	-	-	-	-	-	-	-	-	-	-	-	Endicott Building
SALT LAKE CITY	-	-	-	-	-	-	-	-	-	-	-	McIntyre Building
SAN FRANCISCO	-	-	-	-	-	-	-	-	-	-	-	Pacific Building
TOPEKA	-	-	-	-	-	-	-	-	-	-	-	623 Kansas Avenue



## ASSOCIATED COMPANIES:

THE AMERICAN BRAKE COMPANY,  
St. Louis, Mo.

THE WESTINGHOUSE AIR BRAKE COMPANY,  
Pittsburg, Pa.

CANADIAN WESTINGHOUSE COMPANY, LTD.,  
Hamilton, Ontario, Canada.

WESTINGHOUSE PACIFIC COAST BRAKE  
COMPANY,  
Emeryville, Cal.

WESTINGHOUSE AUTOMATIC AIR AND STEAM  
COUPLER COMPANY,  
St. Louis, Mo.

THE WESTINGHOUSE BRAKE COMPANY, LTD.,  
London, England. Hanover, Germany.

THE WESTINGHOUSE COMPANY, LTD.,  
St. Petersburg, Russia.

SOCIÉTÉ ANONYME WESTINGHOUSE,  
Paris, France.